

Installation

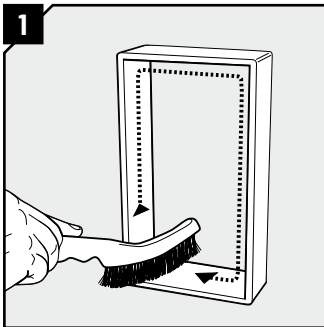

1 Make sure that the inside surfaces of the frame are free from dirt or dust.

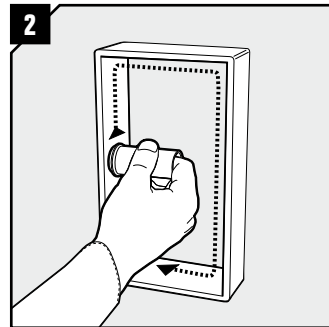

2 Lubricate the inside surfaces of the frame with Roxtec Lubricant, especially into the corners.

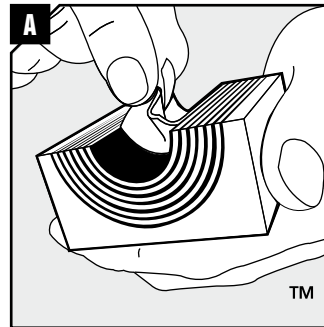

A Adapt modules, which are to hold cables or pipes, by peeling off layers until you reach the gap seen in pic. B. The halves may not differ by more than one layer.

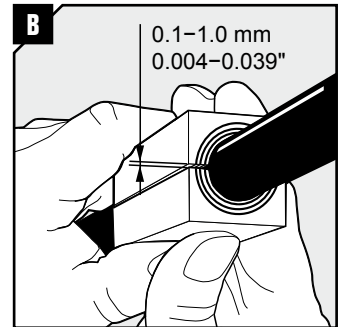

B Achieve a 0.1–1.0 mm gap between the two halves when held against the cable/pipe.

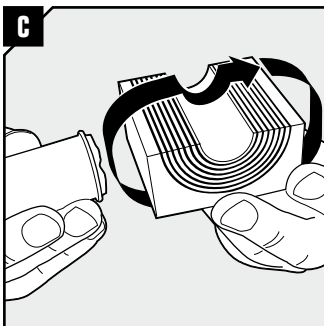

C Lubricate all modules for the frame thoroughly, both the inside and the outside surfaces.

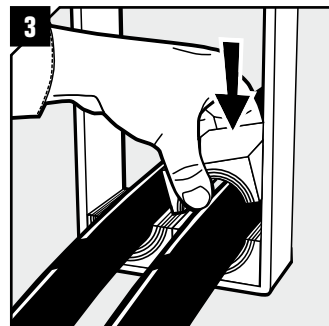

3 Insert the modules according to your installation plan (transit plan). It is recommended to seal cables/pipes at the bottom of the frame and put spare modules on top.

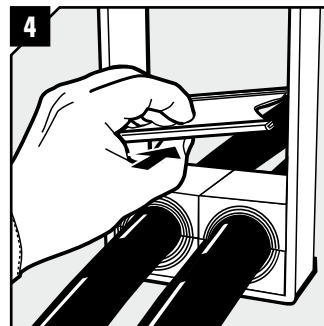

4 Insert a stayplate on top of every finished row of modules.

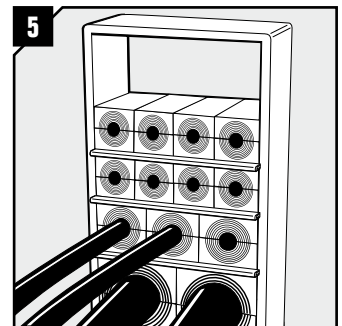

5 Continue to fill up the packing space of the frame, until one final row is left. See pictures "Packing space" for the full size of the space.

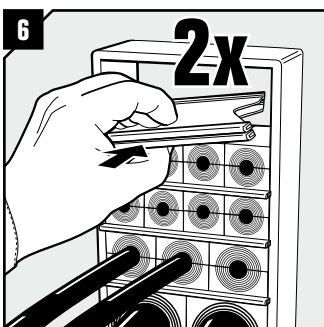

6 Before inserting the final row of modules, insert two stayplates.

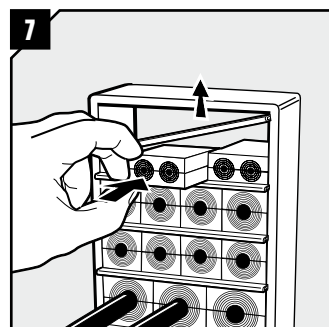

7 Separate the two stayplates and insert the final row of modules between the stayplates.

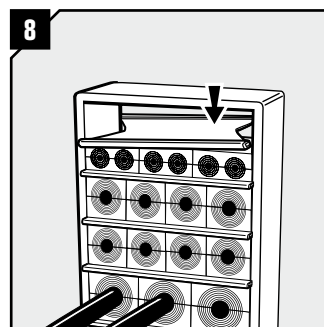

8 Drop the upper stayplate on top of the modules.

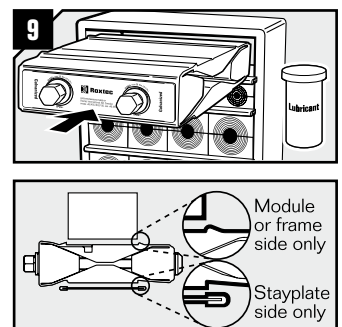

9 Lubricate all sides of the wedge sparsely, except front and back. Please read the markings on the wedge and turn it correctly before inserting it in the top of the frame (standard position). Face with "Stayplate this side" must always face a stayplate.

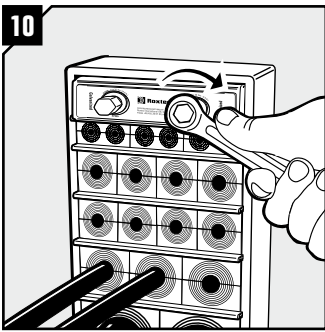

Tighten the screws until full stop, approx 20 Nm (15 ft.lb.).

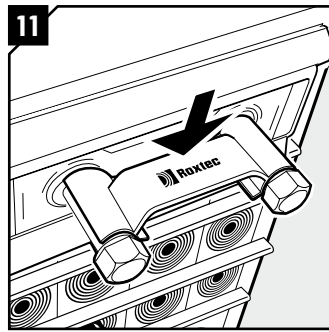

Attach the Wedge Clip to the wedge bolts to check that the wedge is properly tightened.

Installation options and tools

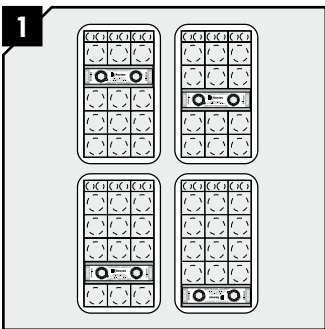

Optional wedge positions (anywhere within the frame).

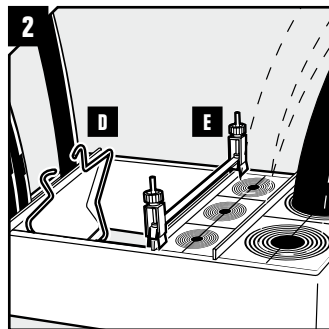

Stayplate clips (D) and stayplate clamps (E) can be used to simplify horizontal assembly.

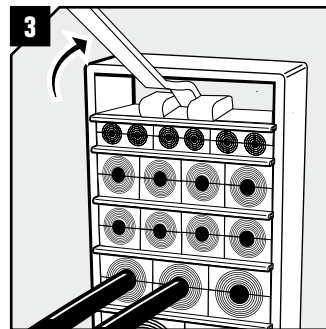

In order to further simplify installation, we provide tools for pre-compression of the modules in the frame. For more information about Roxtec tools, please visit www.roxtec.com.

Disassembly

Reverse order

Packing space

Frame sizes 2, 4, 6 and 8 accommodate the following height of modules: 60 mm, 120 mm, 180 mm and 240 mm. As example shows for frame size 6 the 180 mm can be the result of 4 rows of RM 40 plus one row of RM 20.

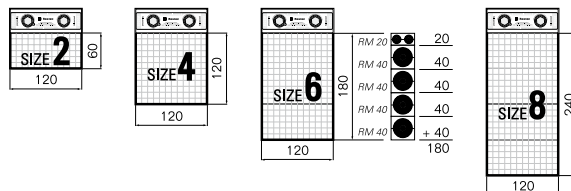

Note

- For optimum reliability, wait 24 hours or longer after installation before exposing the cables/pipes to strain or pressure.
- Wedge is to be used with: RM components.
- To simplify installation in combination frames, fill all openings before tightening the wedge.
- Cables shall go straight through the frame.

DISCLAIMER

"The Roxtec cable entry sealing system ("the Roxtec system") is a modular-based system of sealing products consisting of different components. Each and every one of the components is necessary for the best performance of the Roxtec system. The Roxtec system has been certified to resist a number of different hazards. Any such certification, and the ability of the Roxtec system to resist such hazards, is dependent on all components that are installed as a part of the Roxtec system. Thus, the certification is not valid and does not apply unless all components installed as part of the Roxtec system are manufactured by or under license from Roxtec ("authorized manufacturer"). Roxtec gives no performance guarantee with respect to the Roxtec system, unless (I) all components installed as part of the Roxtec system are manufactured by an authorized manufacturer and (II) the purchaser is in compliance with (a), and (b), below.

(a) During storage, the Roxtec system or part thereof, shall be kept indoors in its original packaging at a temperature not exceeding +70°C/+158°F and not below -40°C/-40°F.

(b) Installation shall be carried out in accordance with Roxtec installation instructions in effect from time to time.

The product information provided by Roxtec does not release the purchaser of the Roxtec system, or part thereof, from the obligation to independently determine the suitability of the products for the intended process, installation and/or use.

Roxtec gives no guarantee for the Roxtec system or any part thereof and assumes no liability for any loss or damage whatsoever, whether direct, indirect, consequential, loss of profit or otherwise, occurred or caused by the Roxtec systems or installations containing components not manufactured by an authorized manufacturer.

Roxtec expressly excludes any implied warranties of merchantability and fitness for a particular purpose and all other express or implied representations and warranties provided by statute or common law. User determines suitability of the Roxtec system for intended use and assumes all risk and liability in connection therewith. In no event shall Roxtec be liable for consequential, punitive, special, exemplary or incidental damages."



Roxtec International AB
 Box 540, 371 23 Karlskrona, SWEDEN
 PHONE +46 455 36 67 00, FAX +46 455 820 12
 EMAIL info@roxtec.com, www.roxtec.com