

Installation

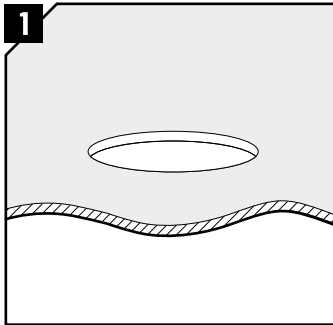

1 Make a hole for the sleeve, according to the rec. hole cut. See table on next page.

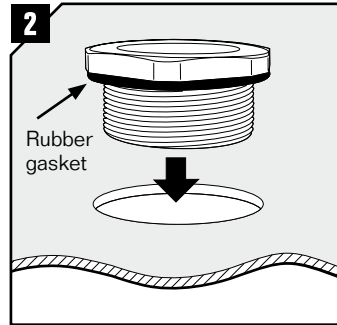

2 Insert the sleeve. Make sure the rubber gasket is in place.

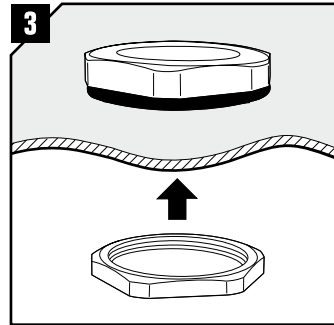

3 Fit the nut from inside, tighten and fasten the sleeve.

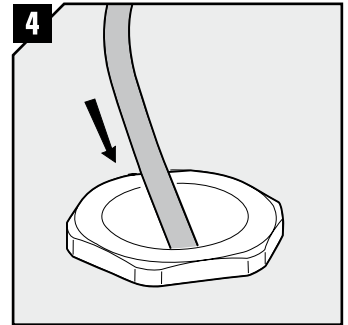

4 Insert the cable/pipe through the sleeve.

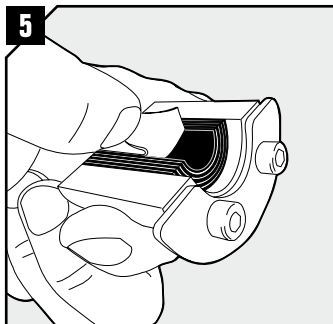

5 Adapt the seal to the cable/pipe by peeling layers from the halves until you reach the gap seen in pic.6.

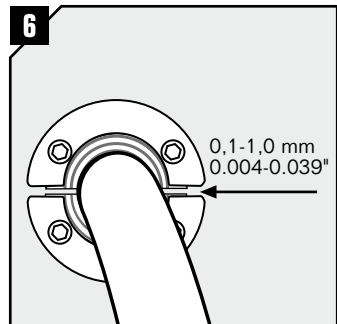

6 Try to achieve a 0.1-1.0 mm gap between the two halves when held against the cable/pipe.

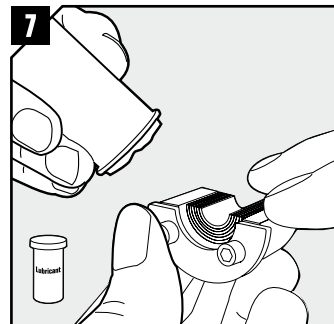

7 Lubricate thoroughly on the inside surfaces and sparsely on the outside of the seal with Roxtec Lubricant.

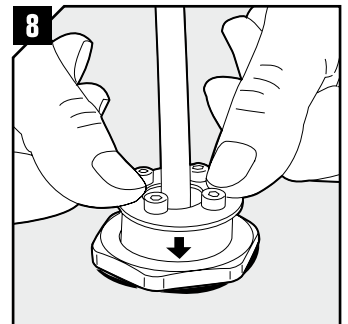

8 Place the seal around the cable and insert it into the sleeve.

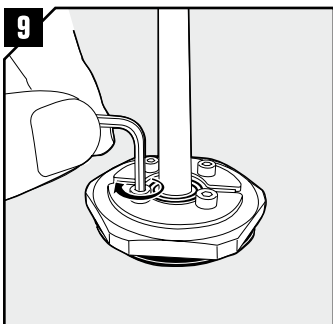

9 Tighten the screws crosswise. The seal will compress and seal the transit.

Type:	Max Torque* (Nm)
C RS T 25	1
C RS T 31	1
C RS T 43	4
C RS T 50	4

* The torque depends on several things e.g. cable or pipe size, amount of used lubricant, sleeve size or material in the cable sheet etc.

Disassembly

Reverse order

Aperture dimensions

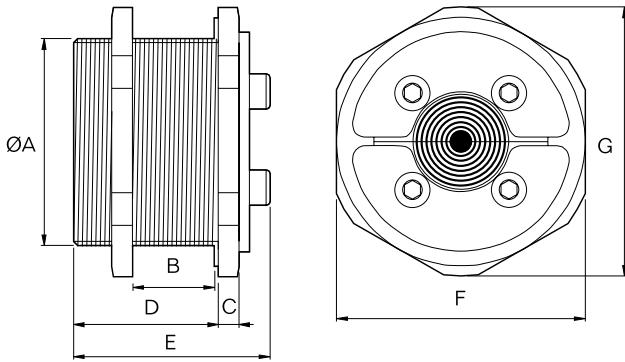

Type	C R S T 25		C R S T 31		C R S T 43		R S T 50	
	(mm)	(in)	(mm)	(in)	(mm)	(in)	(mm)	(in)
Cable range	0+3.6-12.0	0+0.142-0.472	0+4.0-17.0	0+0.175-0.669	0+4.0-23.0	0+0.157-0.906	0+8.0-30.0	0+0.315-1.181
Rec.hole cut Ø	32-33	1.260-1.299	40-41	1.575-1.614	50-51	1.969-2.008	63-64	2.480-2.519
Thread	M32x1.5	M32x1.5	M40x1.5	M40x1.5	M50x1.5	M50x1.5	M63x1.5	M63x1.5
A	32	1.260	40	1.575	50	1.969	63	2.480
B,wall thickness	1-10	0.039-0.394	1-8	0.039-0.315	1-28	0.039-1.102	1-26	0.039-1.024
C	4	0.157	5	0.197	5	0.197	6	0.236
D	16	0.630	15	0.591	35	1.378	34	1.339
E	25	0.984	25	0.984	48	1.890	48	1.890
F	36	1.417	46	1.811	60	2.362	70	2.756
G	39	1.535	50	1.969	65	2.559	78	3.071

Note

- For optimum reliability, wait 24 hours or longer after installation before exposing the cables/pipes to strain or pressure.
- Cables/pipes shall go straight through the frame.

DISCLAIMER

"The Roxtec cable entry sealing system ("the Roxtec system") is a modular-based system of sealing products consisting of different components. Each and every one of the components are necessary for the best performance of the Roxtec system. The Roxtec system has been certified to resist a number of different hazards. Any such certification, and the ability of the Roxtec system to resist such hazards, is dependent on all components that are installed as a part of the Roxtec system. Thus, the certification is not valid and does not apply unless all components installed as part of the Roxtec system are manufactured by or under license from Roxtec ("authorized manufacturer"). Roxtec gives no performance guarantee with respect to the Roxtec system, unless (i) all components installed as part of the Roxtec system is manufactured by an authorized manufacturer and (ii) the purchaser is in compliance with (a), and (b), below.

(a) During storage, the Roxtec system or part thereof, shall be kept indoors in its original packaging at a temperature not exceeding +70°C/+158°F and not below -40°C/-40°F.

(b) Installation shall be carried out in accordance with Roxtec installation instructions in effect from time to time.

The product information provided by Roxtec does not release the purchaser of the Roxtec system, or part thereof, from the obligation to independently determine the suitability of the products for the intended process, installation and/or use.

Roxtec gives no guarantee for the Roxtec system or any part thereof and assumes no liability for any loss or damage whatsoever, whether direct, indirect, consequential, loss of profit or otherwise, occurred or caused by the Roxtec systems or installations containing components not manufactured by an authorized manufacturer.

Roxtec expressly excludes any implied warranties of merchantability and fitness for a particular purpose and all other express or implied representations and warranties provided by statute or common law. User determines suitability of the Roxtec system for intended use and assumes all risk and liability in connection therewith. In no event shall Roxtec be liable for consequential, punitive, special, exemplary or incidental damages."



Roxtec International AB
 Box 540, 371 23 Karlskrona, SWEDEN
 PHONE +46 455 36 67 00, FAX +46 455 820 12
 EMAIL info@roxtec.com, www.roxtec.com