



Description and application guidelines

Technical guidelines for Roxtec BG™ sealing solutions

Prepared for: Roxtec International AB

Date: 2026-04-21

Author: Mikael Grudd, Roxtec Group,
Box 540, Karlskrona, Sweden

[roxtec.com](https://www.roxtec.com)

Contents

1	Intended applications	3
2	Tests and certifications	3
3	Cables	4
3.1	Considerations	4
3.2	Cable retention	4
4	Roxtec frames	5
4.1	Regular frames for Roxtec BG™ modules	5
4.2	Compact frames for Roxtec BG™ modules	5
4.3	Regular frames for Roxtec BG™ Ex modules	6
4.4	Compact frames for Roxtec BG™ Ex modules	6
5	Roxtec BG™ modules	7
5.1	Roxtec BG™ B module	7
5.2	Roxtec BG™ module	7
5.3	Braid data per module size	8
5.4	Current and surge withstand capabilities per module size	8
6	Roxtec seals	8
6.1	Roxtec BG™ seals	8
6.2	Sleeves for Roxtec BG™ seals	9
6.3	Braid data per RS BG seal size	9
6.4	Current and surge withstand capabilities per seal size	9
7	Contact resistance and impedance	10







1 Intended applications

The Roxtec BG™ product family is designed to safely and efficiently bond or ground armored and shielded cables through a single cut-out or opening in a wall, floor or electrical enclosure. The product provides a secure means of cable terminations and pass-throughs, provides an environmental and fire resistant seal, and establishes a secure bonding path to ground for metallic cable components. The product is certified for use in hazardous locations where required by local codes and regulations. The Roxtec BG™ system complies with EU directive 2011/65/EU, Restriction of Hazardous Substances (RoHS).

The Roxtec BG™ product line is suitable for use in applications in the following industries:

- Oil, gas and petrochemicals
- Marine
- Nuclear and power generation
- Telecom
- Original equipment manufacturing
- Construction

2 Tests and certifications

Certifying authority	Type of certificate
 CSA List file 215242	ORDINARY LOCATIONS Canadian standards – Environmental rating: 1, 2, 3, 3R, 3S, 4, 4X, 5, 12, 13, CAN/CSA 22.2 No.94.2 – Bonding and Grounding: CAN/CSA 22.2. No. 18.3-04, No. 41-07 US standards – Environmental (NEMA) rating: 1, 2, 3, 3R, 3S, 4, 4X, 5, 12, 13, UL 50 – Bonding and Grounding: UL514B and UL467 HAZARDOUS LOCATIONS – Canada: Ex e IIC – USA: AEx e IIC Class I, Zone 1
 List file R15556	Firestop device UL 1479
	IECEx Certificate of Conformity EC-type examination certificate (ATEX) – II 2G Ex e IIC Gb, II 2D Ex tb IIIC Db, IP6X ("X" depending on type of frame) – Compliance of standards: EN 60079-0:2012, EN 60079-7:2007, EN 60079-31:2009, IEC 60079-0:2011, IEC 60079-7:2006, IEC 60079-31:2008
  	A-class Steel bulkhead/deck
	H-class Steel bulkhead/deck

Test lab	Type of test
SAAB Technologies (SE)	Earth continuity IEC 60079-0, p26.12 Contact/transfer impedance and shielding effectiveness VG 95373 p15, EN 50147-1
Global Lightning Protection Services (DK)	Short circuit and current withstand capabilities EN 50262 / IEC 62444 Current surge IEC 62305 Earthing efficiency
Spiez Laboratory (CH)	Blast load
Southwest Research Institute (US)	Gas tightness Blast load
IMQ (IT)	Cable anchorage, impact, short current and IP IEC 62444
DEHN (DE)	IEC 62561-1: Lightning protection system components (LPSC) - Part 1: Requirements for connection components

The tables include certifications obtained at the moment for publishing this paper. The list is continuously updated, please check roxtec.com/certificates for the most recent additions. All tests and certifications are valid only for a complete Roxtec system correctly installed according to installation instructions and for the systems included in the respective test report and certificate.

3 Cables

The module is designed for use with a wide variety of cables where the protective armor or shield has to be connected to ground meeting requirements for bonding and grounding in electrical installations. During the test and certification process, the products have been tested with:

- Cables with a circular cross-section such as, wire and braided armored cables (..WA, ..WB), smooth metal tubes and foil sheeted cables.
- Continuous welded and interlocking armored cables such as, MC, MC-HL, TECK, AC, ACWU and ACIC.

3.1 Considerations

IEC 60079-14 calls for circular cables having a solid inner core to be used to avoid cold flow. As all compression type sealing systems exert a pressure, soft bedded cables should be avoided.

3.2 Cable retention

Roxtec systems are certified according to EN/IEC 60079-0, EN/IEC 60079-7 and EN/IEC 60079-31.

4 Roxtec frames

The following frames are certified to be equipped with Roxtec BG™ modules. For more information, please see roxtec.com.

4.1 Regular frames for Roxtec BG™ modules



S frame



SF frame



SK frame



SBTB frame



GH BG frame



GH BG FL100 frame

4.2 Compact frames for Roxtec BG™ modules

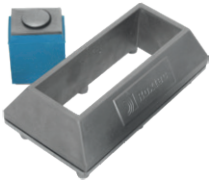

CF 8 BG frame

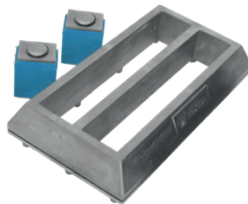

CF 32 BG frame

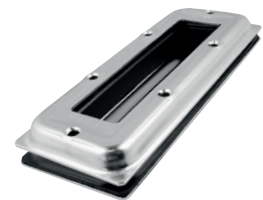

CF 16 BG frame

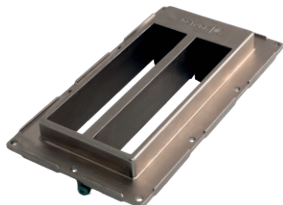

ComSeal 32 BG frame



HD 16 frame*

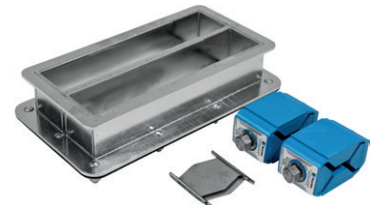

HD 32 frame*

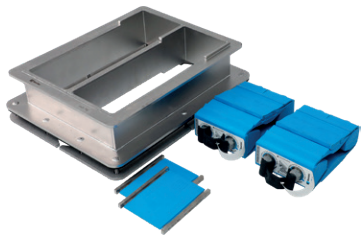

HD 72 frame*



CSP 16 frame*



CSP 32 frame*

*Same frame as for standard modules.

4.3 Regular frames for Roxtec BG™ Ex modules



S Ex frame



G BG Ex frame



G..W Ex frame

4.4 Compact frames for Roxtec BG™ Ex modules



CF 8 BG Ex frame

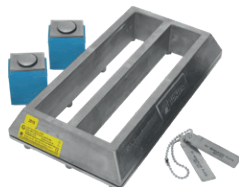

CF 32 BG Ex frame



HD 16 Ex frame*



HD 32 Ex frame*

*Same frame as for Ex modules.

Note:

Applications where the frame is mounted to a non-conductive surface require an additional bonding conductor to ensure continuity to ground. Always refer to applicable electrical installation code, standards and laws.

5 Roxtec BG™ modules

The Roxtec BG™ sealing modules for bonding and grounding in electrical installations exist in regular (RM) and compact (CM) versions. They all provide electrical safety and environmental protection as well as adaptability for a perfect fit to cables and pipes with an OD of 3.5–99.0 mm for RM modules and 3.5–34.5 mm for CM modules.

The Roxtec BG™ modules are also available in Ex approved versions as well as in pre-configured kits.

5.1 Roxtec BG™ B module

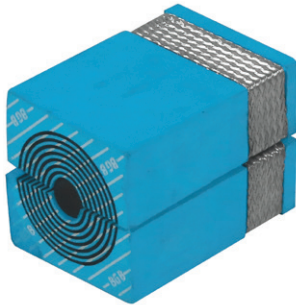

The Roxtec BG™ B module is mainly intended for use when environmental protection is required from one side only, such as cable terminations into enclosures and cabinets. Available in RM and CM versions.

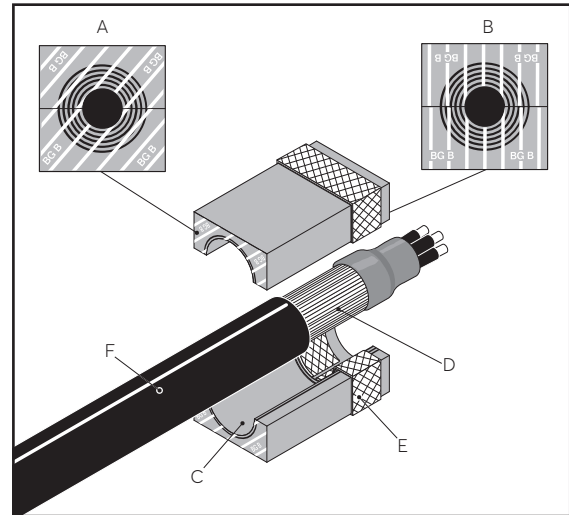

A: Environmental side
 B: Termination/interior side
 C: Removable layers
 D: Cable armor
 E: Module braid
 F: Cable jacket

5.2 Roxtec BG™ module

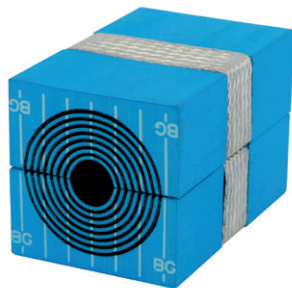

The Roxtec BG™ module is mainly intended for use where environmental protection is required from both sides with regular frames for pass-throughs. Available in RM version.

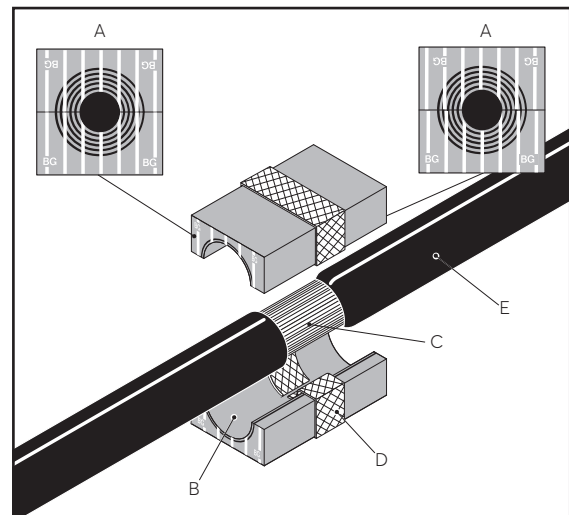

A: Environmental side
 B: Removable layers
 C: Cable armor
 D: Module braid
 E: Cable jacket

5.3 Braid data per module size

BG module size	Cable range (outer Ø mm)	Total braid cross-section (mm ²)	Approximately equivalent AWG
20w40	3.5–16.5	4	11
20	4–14.5	8	8
30/30w40	10–25	13	6
40 10–32	9.5–32.5	21	4
40	21.5–34.5	42	4
60 24–54	24–54	42	1
60	28–54	42	1
80/90	48–71	42	1
120	67.5–99	42	1

5.4 Current and surge withstand capabilities per module size

BG module size	AC SHORT CIRCUIT TEST					CURRENT SURGE TEST*	
	UL 514B/UL 467, CSA 22.2 No 18.3-04/No 41.07 requirements		Tested to:		EN 50262,/A1,/A2 Armored cables Category B current req. A, 1sec	Tested to A, 1 sec	IEC 62305-1, pulse shape 10/350us. Tested to (kA):
	Current (A)	Sec	Current (A)	Sec			
20w40	1180	4	1530	6	Cat A, 500	500	50
20	1180	4	1530	6	3060	3480	100
30/30w40	1530	6	1530	6	4000	4101	100
40/40 10–32	2450	6	2450	6	5400	5409	100
60/60 24–54	4900	6	5050	9	7200	7495	200
80/90	5050	9	5050	9	10400	15274	200
120	5050	9	8030	9	10400	15274	200

*Tested in rectangular regular frames type S, G.

6 Roxtec seals

6.1 Roxtec BG™ seals



RS BG seal

6.2 Sleeves for Rextec BG™ seals



SLF RS BG sleeve

6.3 Braid data per RS BG seal size

RS BG seal size	Cable range (outer Ø mm)	Total braid cross-section (mm ²)	Approximately equivalent AWG
25	3.6–12	13	6
31	4.0–17	13	6
43	4.0–23	13	6
50	8.0–30	24	4
68	26.0–48	42	1
75	24.0–54	42	1
100	48.0–70	42	1
125	66.0–98	42	1
150	93.0–119	42	1

6.4 Current and surge withstand capabilities per seal size

RS BG seal size	AC SHORT CIRCUIT TEST						CURRENT SURGE TEST
	UL 514B/UL 467, CSA 22.2 No 18.3-04/No 41.07 requirements		Tested to:		EN 50262, /A1, /A2 Armored cables Category B current req. A, 1sec	Tested to A, 1 sec	IEC 62305-1, pulse shape 10/350us. Tested to (kA):
	Current (A)	Sec	Current (A)	Sec			
25	1180	4	3500	6	3060	3965	100
31	1530	6	3500	6	3060	3965	100
43	1530	6	3500	6	3060	3965	100
50	2450	6	4900	6	4000	4900	100
68	3900	6	5050	9	7200	10400	200
75	4900	6	5050	9	7200	10400	200
100	5050	9	5050	9	10400	10400	200
125	5050	9	5050	9	10400	10400	200
150	5050	9	5050	9	10400	10400	200

7 Contact resistance and impedance

Resistance measured between an armor and the earthing point/lug is for Roxtec BG™ B/BG™ systems <1mOhm for aluminum, mild and galvanized steel frames and <2mOhm for stainless steel frames measured @10A DC.

Transfer impedance from cable armor to frame is <10mOhm up to 30MHz per first graph below.

The dynamic range for the test setup given as a dotted blue reference line.

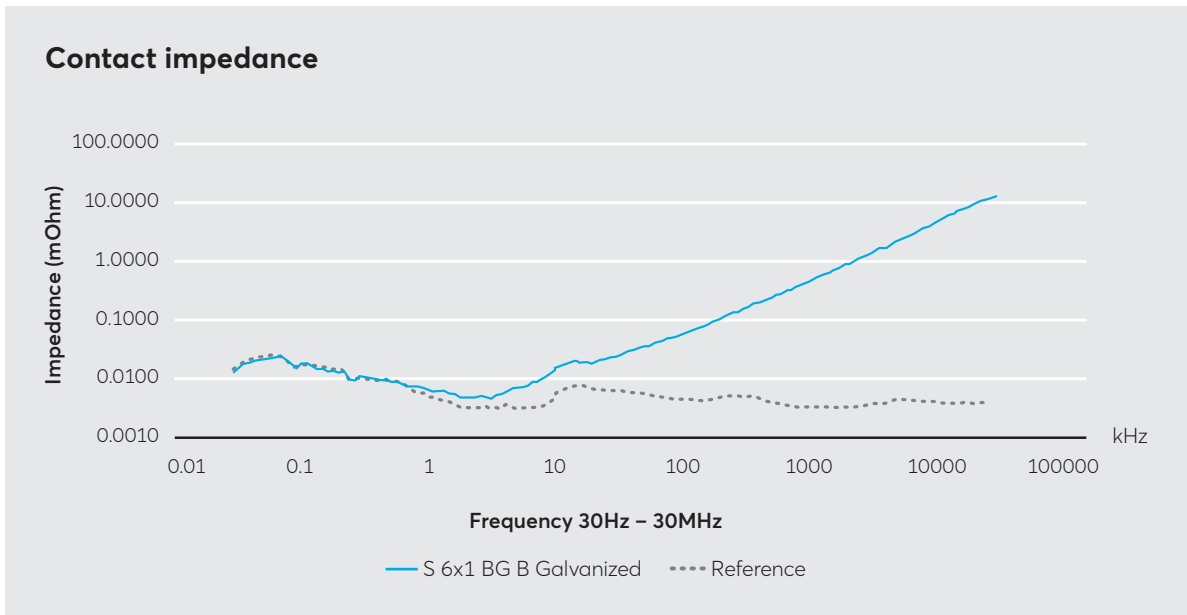

DISCLAIMER

*The Roxtec cable and pipe entry sealing system ('the Roxtec system') is a modular-based system of sealing products consisting of different components. Each and every one of the components is necessary for the best performance of the Roxtec system. The Roxtec system has been certified to resist a number of different hazards. Any such certification, and the ability of the Roxtec system to resist such hazards, is dependent on all components that are installed as a part of the Roxtec system. Thus, the certification is not valid and does not apply unless all components installed as part of the Roxtec system are manufactured by or under license from Roxtec ('authorized manufacturer'). Roxtec gives no performance guarantee with respect to the Roxtec system, unless (I) all components installed as part of the Roxtec system are manufactured by an authorized manufacturer and (II) the purchaser is in compliance with (a), and (b), below.

(a) During storage, the Roxtec system or part thereof, shall be kept indoors in its original packaging at room temperature.

(b) Installation shall be carried out in accordance with Roxtec installation instructions in effect from time to time.

The product information provided by Roxtec does not release the purchaser of the Roxtec system, or part thereof, from the obligation to independently determine the suitability of the products for the intended process, installation and/or use.

Roxtec gives no guarantee for the Roxtec system or any part thereof and assumes no liability for any loss or damage whatsoever, whether direct, indirect, consequential, loss of profit or otherwise, occurred or caused by the Roxtec systems or installations containing components not manufactured by an authorized manufacturer and/or occurred or caused by the use of the Roxtec system in a manner or for an application other than for which the Roxtec system was designed or intended.

Roxtec expressly excludes any implied warranties of merchantability and fitness for a particular purpose and all other express or implied representations and warranties provided by statute or common law. User determines suitability of the Roxtec system for intended use and assumes all risk and liability in connection therewith. In no event shall Roxtec be liable for indirect, consequential, punitive, special, exemplary or incidental damages or losses.

The Roxtec products are offered and sold in accordance with the conditions of the Roxtec General Terms of Sales. The latest version of the Roxtec General Terms of Sales can be found and downloaded from roxtec.com/general-terms-of-sales.*

