



Description and application guidelines

Roxtec selection guide – gaskets for electromagnetic shielding applications

Prepared for: Roxtec International AB

Date: 2026-05-11

Author: Mikael Grudd, Roxtec Group,
Box 540, Karlskrona, Sweden

[roxtec.com](https://www.roxtec.com)

Contents

1	Electromagnetic shielding	3
1.1	Materials of bolts	3
1.2	Distance between bolts	3
2	Frames for Roxtec ES solutions	4
2.1	Rectangular frames	4
2.2	Round frames	4
3	Conductive gaskets	4
3.1	Conductive gasket – self-adhesive solid knitted wire mesh – round with fin AISI316	4
3.2	Conductive gasket – solid knitted wire mesh – twin round with fin AISI316	5
3.3	Conductive gasket – fabric over foam – D-list 9.5x6.4mm	6
4	Ingress protection, IP	7
4.1	Single side ingress protection	7
4.2	Dual side ingress protection	8
5	Corrosion	9
5.1	Controlled environment	9
5.2	Uncontrolled environment	9
5.3	Marine environment	9
6	Walls	9

1 Electromagnetic shielding

To ensure electromagnetic shielding, electrically conductive materials must be used on all sides of the enclosure or structure, for example metal or wire mesh. When installing a cable or pipe transit device in an electromagnetic shielding application, the metal frame needs to be a part of the structure forming the electrical barrier. A continuous electrical connection between the frame and the structure must be ensured. The best method is to weld the frame to the surrounding metallic wall. In this case, it is possible to achieve both the electrical shielding properties as well as water, gas and fire protection.

Bolting is preferred, however, when it is not allowed or practical to weld the frame to the structure. This guide will treat how to maintain the shielding protection when using bolted transits.

1.1 Materials of fastening bolts

The bolts shall have proper electrical contact with both the frame and the structure. Therefore, it is important to select bolts with proper surface treatment. If the surface treatment is electrically isolating the bolts, it can reduce the shielding performance of the system.

1.2 Distance between bolts

To maintain shielding performance, it is important to have an even compression level for the conductive gasket. The conductive gasket usually requires a lot of force for correct compression, which can lead to deflection of the frame or structure. Therefore, it is important to use a hole pattern with small spacing.

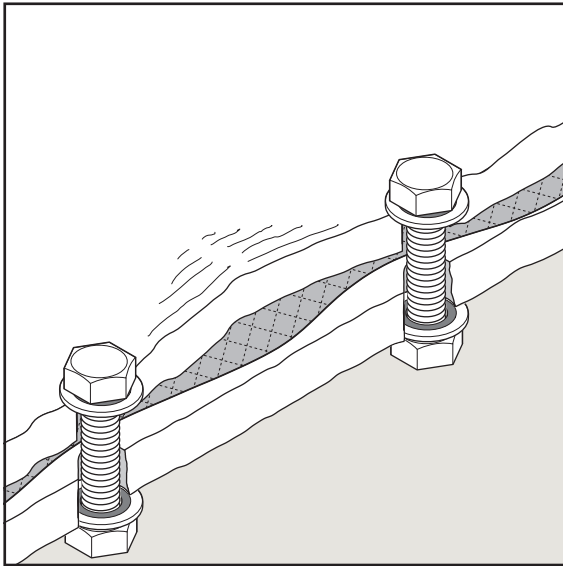

2 Frames for Roxtec ES solutions

The frame must be free from paint to ensure electrical continuity. Roxtec recommends using frames/sleeves of stainless steel, galvanized mild steel or aluminum.

2.1 Rectangular frames

Roxtec recommends the GHM frame for electromagnetic shielding applications. This frame has a suitable hole pattern for shielding applications and is available in both stainless steel and galvanized mild steel.



GHM frame

2.2 Round frames

Roxtec offers round frames called sleeves, both for the R and RS series of the ES system. These sleeves are available in stainless steel, galvanized mild steel and aluminum.



SLFR sleeve

3 Conductive gaskets

To ensure continuous electrical contact in a bolted system, a conductive gasket must be used. There are many types of gaskets and materials that can be used for this purpose. Roxtec can supply several types upon request. These gaskets are typically sold as strips and the length is specified by the customer.

3.1 Conductive gasket – self-adhesive solid knitted wire mesh – round with fin AISI316

Ø6.4mm, fin width W 9.5mm, solid knitted wire mesh. Suitable for shielding effectiveness up to 60dB. A 10mm wide dual adhesive tape needs to be applied on the gasket before installation.

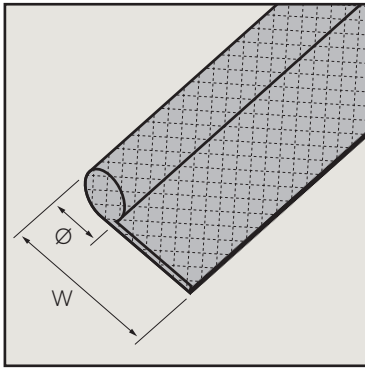

Conductive gasket – round with fin.

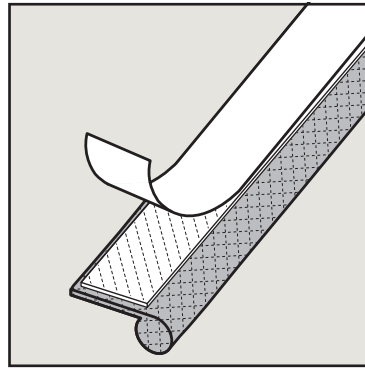

Add adhesive tape.

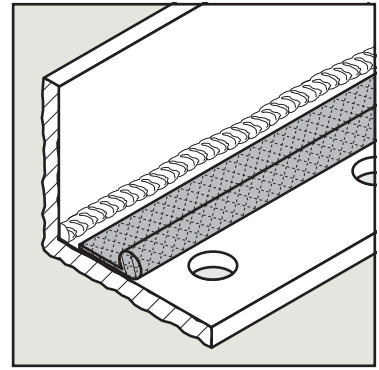

Attach the self-adhesive gasket with the round part facing the bolt holes.

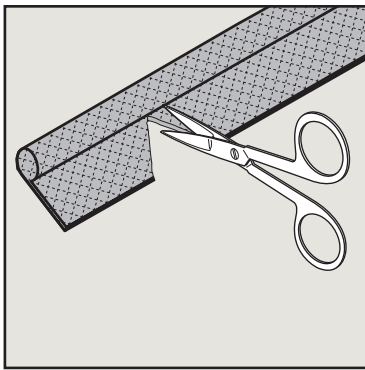

In the corners, cut a 90° slot in the fin before mounting.

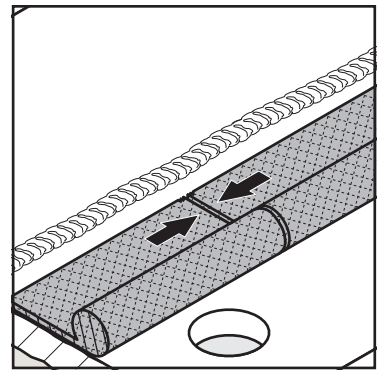
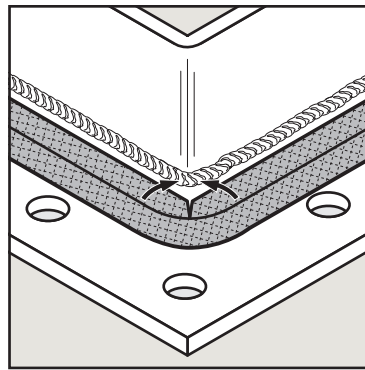

Ensure that the ends of the gasket meet.

3.2 Conductive gasket – solid knitted wire mesh – twin round with fin AISI316

Ø6.4mm, width W 19.1mm, solid knitted wire mesh. Suitable for shielding effectiveness up to 80dB. For best possible performance, make a hole for the fastening bolts between the two round parts of the gasket.

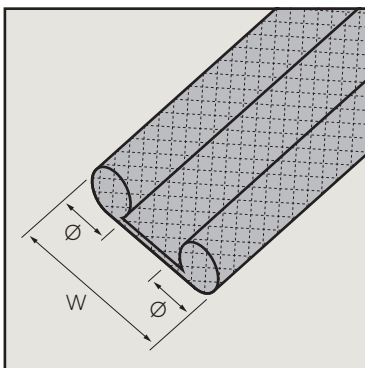

Conductive gasket – twin round with fin.

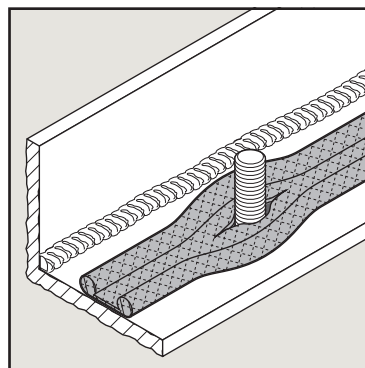

Make a hole and thread through the bolt.

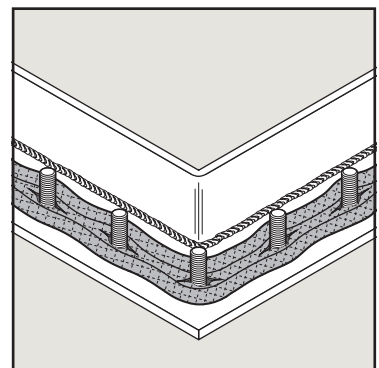

Route the gasket all around the frame.

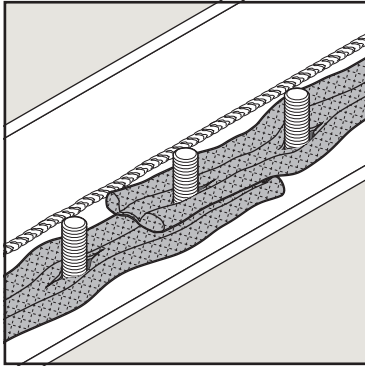

Ensure an overlap of minimum 20mm for the gasket joint.

3.3 Conductive gasket – fabric over foam – D-list 9.5x6.4mm

Fabric over foam, height, H, 6.4mm, width, W, 9.5mm. Supplied with adhesive tape for easy mounting. Suitable for shielding effectiveness up to 60dB. Recommended compression max. 70%.

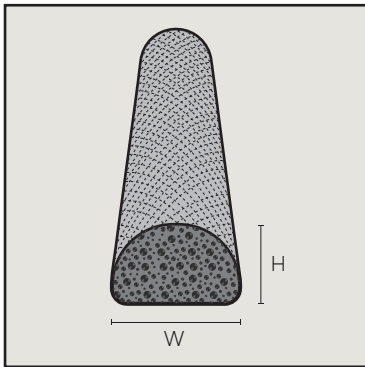

Conductive gasket – fabric over foam.

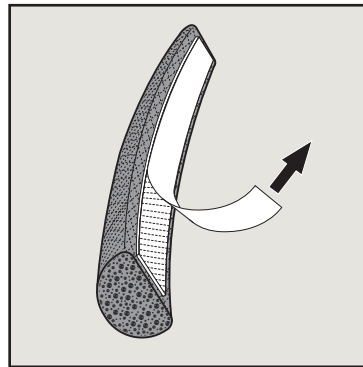

Remove the protection paper.

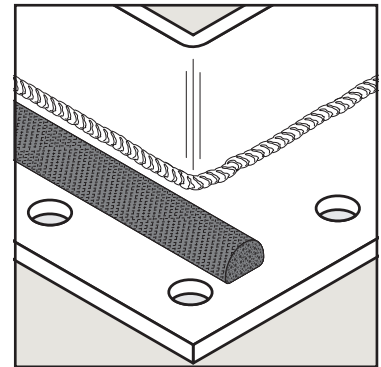

Attach the self-adhesive gasket on the flange.

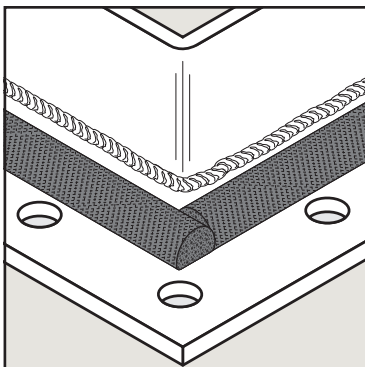

Jointing of gasket ends.

For higher shielding effectiveness, welding is preferred.

Contact your Roxtec representative for guidance and more options.

4 Ingress protection, IP

To obtain ingress protection in combination with electromagnetic shielding, the conductive gasket needs to be combined with an environment gasket.

The knitted wire mesh gasket requires high compression to provide maximum shielding effectiveness. The recommendation is to use sealant or butyl in combination with sealing washers.

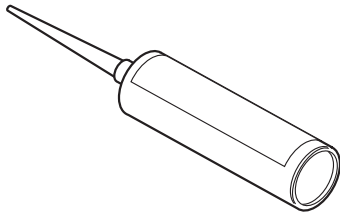

Sealant

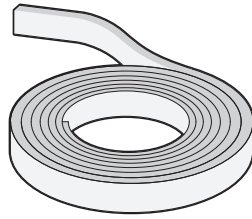

Butyl sealant

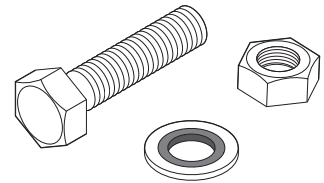

Fastener bolt with sealing washer and nut

4.1 Single side ingress protection

Up to IP 66/67

Sealant

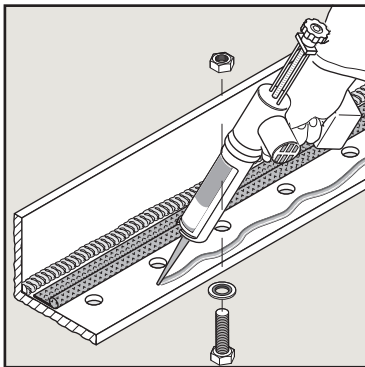

Apply sealant along the outside of the flange in combination with sealing washers.

4.2 Dual side ingress protection

Up to IP 68

Sealant

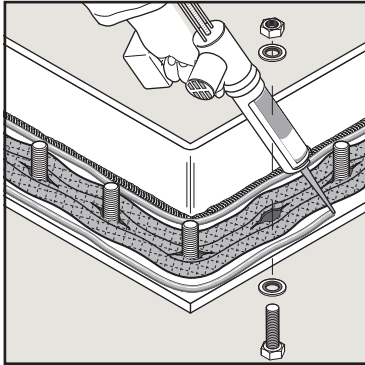

Apply sealant along both the outside and inside of the flange in combination with sealing washers.

Butyl gasket

Apply butyl along both the outside and inside of the conductive gasket in combination with sealing washers.

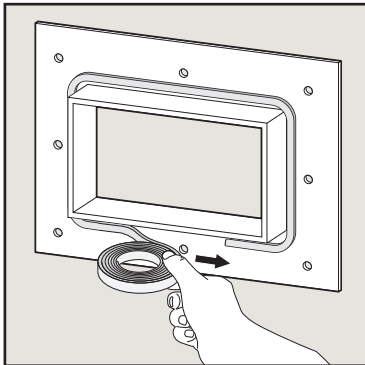

Apply the first round of the butyl gasket on the frame.

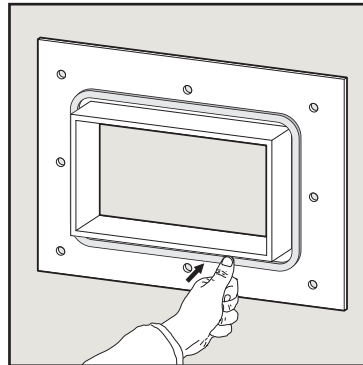

Overlap the ends and secure by hand force.

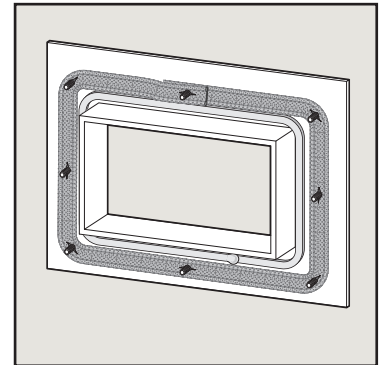

Mount the conductive gasket and bolts with sealing washers.

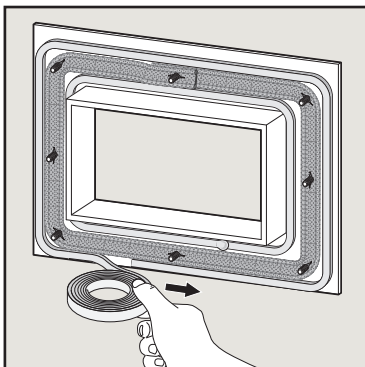

Apply the second round of butyl gasket on the frame.

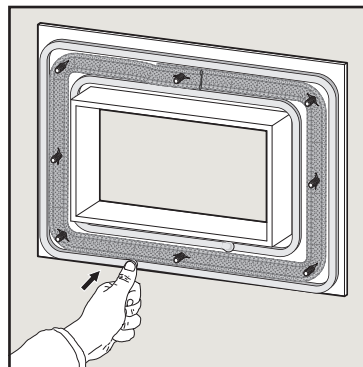

Overlap the ends and secure by hand force.

5 Corrosion

All metals are subject to corrosion. Depending on the surrounding environment, different types of protection are required to avoid the effects of corrosion and to ensure shielding performance over time.

5.1 Controlled environment

Indoor environment with controlled temperature and humidity. Usually only conductive gaskets are used, no environmental protection required.

5.2 Uncontrolled environment

Outdoor environment with uncontrolled temperature and humidity with occasional water presence. Ingress protection with sealant is recommended.

5.3 Marine environment

Environment with salt. Bolting is not a recommended method in harsh environments. Welding is preferred.

6 Walls

For electromagnetic shielding applications, the wall structure must be electrically conductive. Paint, rust, corrosion and dirt must be removed to ensure electrical continuity to the transit frame. The wall structure needs to be thick enough to avoid deflection. Counter flanges are available upon request. Before assembly, the contact surface between the frame and wall structure must be carefully cleaned to enable maximum performance.

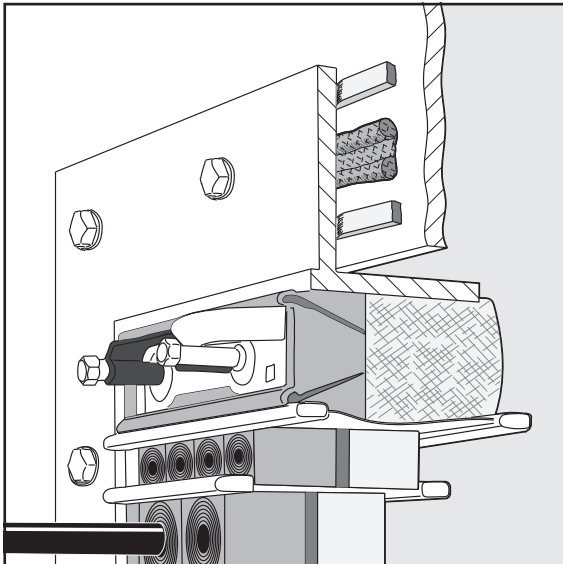

Disclaimer

"The Roxtec cable and pipe entry sealing system ('the Roxtec system') is a modular-based system of sealing products consisting of different components. Each and every one of the components is necessary for the best performance of the Roxtec system. The Roxtec system has been certified to resist a number of different hazards. Any such certification, and the ability of the Roxtec system to resist such hazards, is dependent on all components that are installed as a part of the Roxtec system. Thus, the certification is not valid and does not apply unless all components installed as part of the Roxtec system are manufactured by or under license from Roxtec ('authorized manufacturer'). Roxtec gives no performance guarantee with respect to the Roxtec system, unless (I) all components installed as part of the Roxtec system are manufactured by an authorized manufacturer and (II) the purchaser is in compliance with (a), and (b), below.

(a) During storage, the Roxtec system or part thereof, shall be kept indoors in its original packaging at room temperature.

(b) Installation shall be carried out in accordance with Roxtec installation instructions in effect from time to time.

The product information provided by Roxtec does not release the purchaser of the Roxtec system, or part thereof, from the obligation to independently determine the suitability of the products for the intended process, installation and/or use.

Roxtec gives no guarantee for the Roxtec system or any part thereof and assumes no liability for any loss or damage whatsoever, whether direct, indirect, consequential, loss of profit or otherwise, occurred or caused by the Roxtec systems or installations containing components not manufactured by an authorized manufacturer and/or occurred or caused by the use of the Roxtec system in a manner or for an application other than for which the Roxtec system was designed or intended.

Roxtec expressly excludes any implied warranties of merchantability and fitness for a particular purpose and all other express or implied representations and warranties provided by statute or common law. User determines suitability of the Roxtec system for intended use and assumes all risk and liability in connection therewith. In no event shall Roxtec be liable for indirect, consequential, punitive, special, exemplary or incidental damages or losses.

The Roxtec products are offered and sold in accordance with the conditions of the Roxtec General Terms of Sales. The latest version of the Roxtec General Terms of Sales can be found and downloaded from roxtec.com/general-terms-of-sales."

