

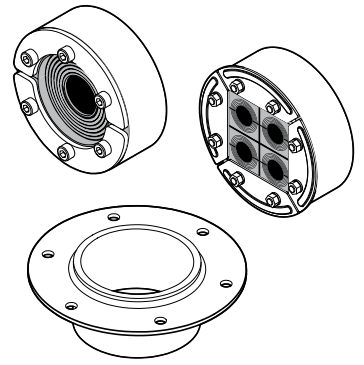

Installation checklist for Roxtec round transits and seals



Checkpoints

-  Correct installation
-  Incorrect installation

Important

These lists of installation checkpoints can be used to visually assess a Roxtec cable/pipe transit sealing system installation. The check is performed to visually verify the correctness of an installation, not a commissioning or functional inspection. The verifications shall be performed and evaluated with the understanding that not all installation errors can be visually detected, even if it is a great help in the quality assurance work. The installation check is limited to those areas and sections of the installation to which reasonable access is both available and permitted at the date of checking. The scope of these installation checkpoints is limited to the transit (frame, modules, stay-plates and wedge). Consequently, it does not cover the attachment of the transit to the structure in question, e.g. insulation required, nor the correctness, quality or routing of cables/pipes. If possible, perform the installation check from both sides of the transit.

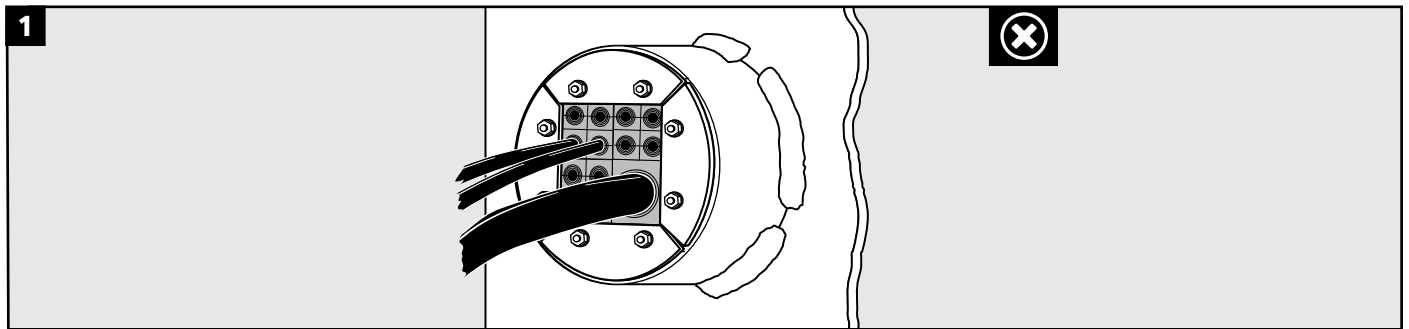

Check that the transit and packing system have no mechanical damages. Also check surface protection and welds if applicable. For welds, see Roxtec welding guidelines.

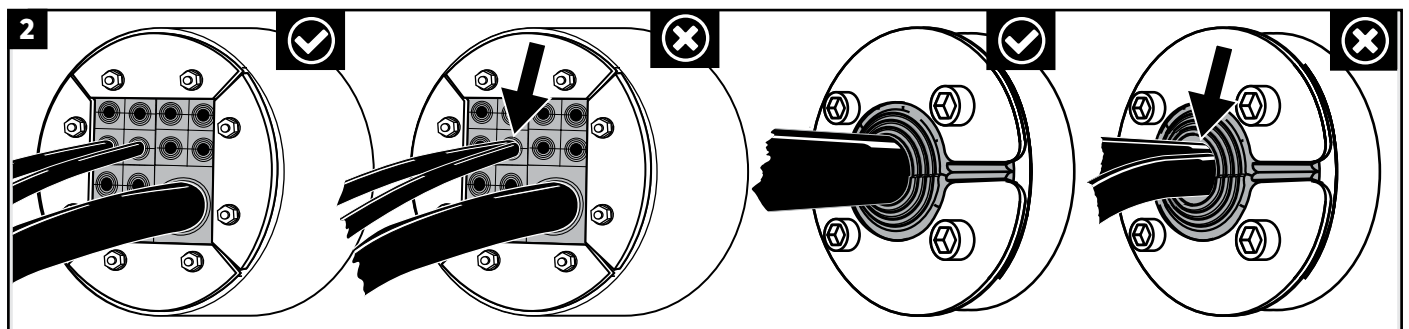

Check that only one cable/pipe passes through each module or opening in a module.

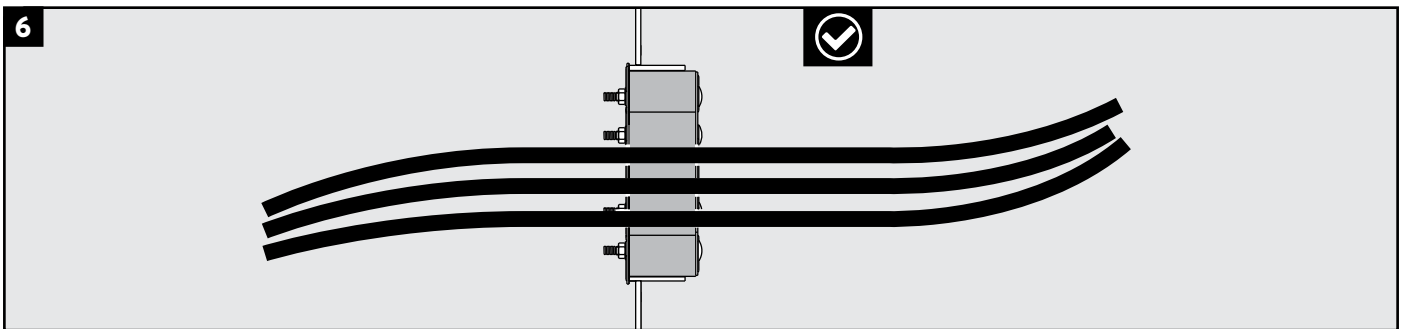
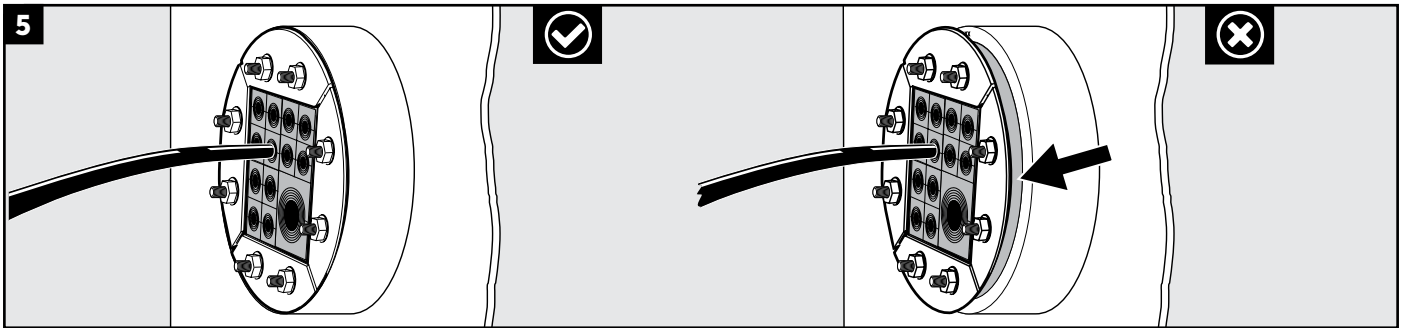
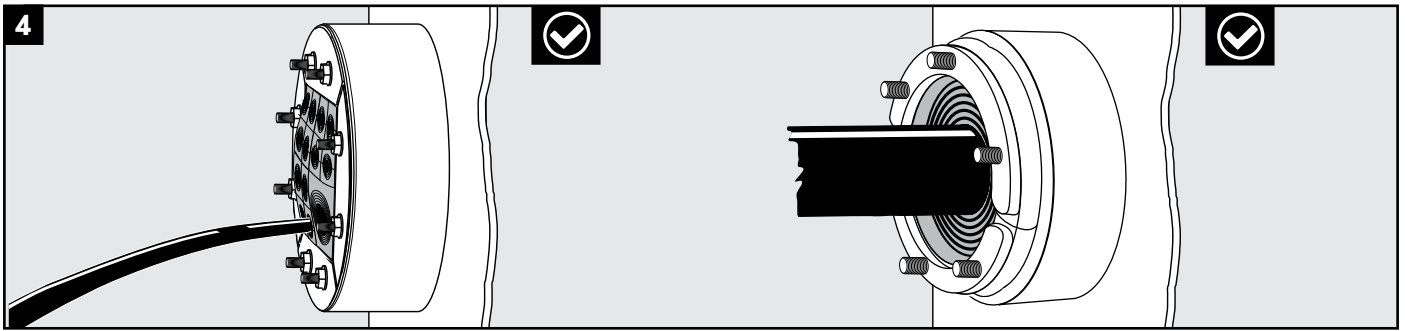
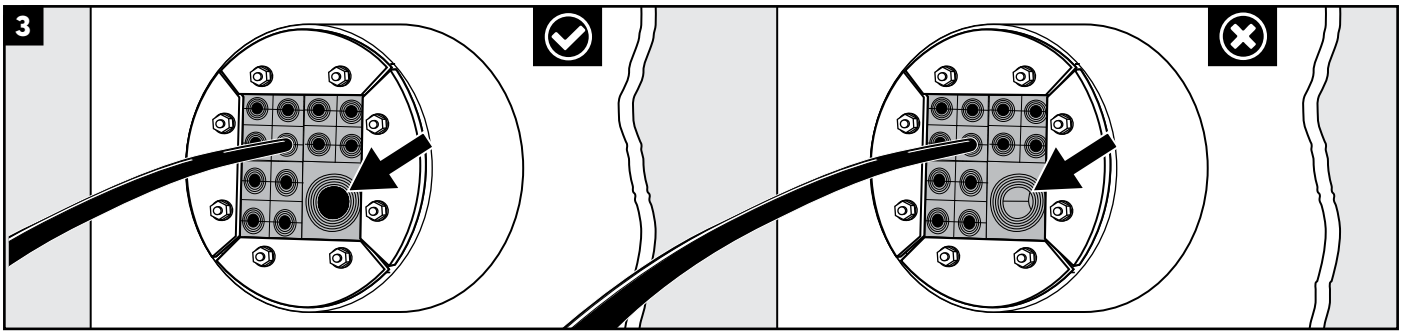

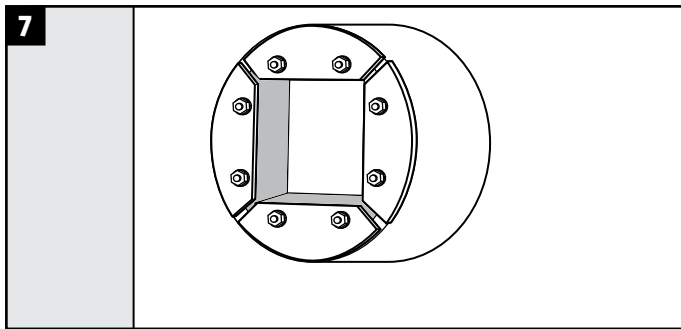

Name	Packing space (mm)
R 50	30 x 30
R 70	40 x 40
R 75	40 x 40
R 100	60 x 60
R 125	80 x 80
R 127	80 x 80
R 150	90 x 90
R 200	120 x 120

For R frames:
Verify the correct utilization of the entire packing space.

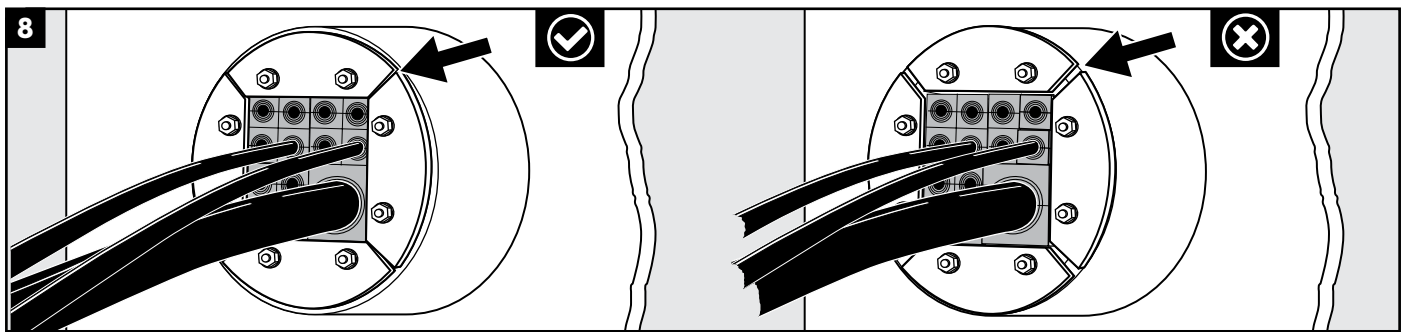

Make sure that the front fittings are positioned so that the modules are retained.

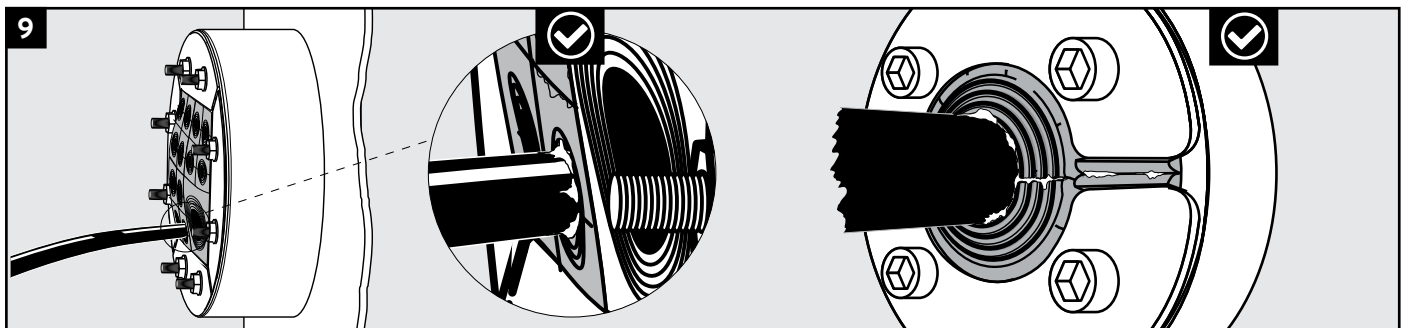

Check the compression. The transit is compressed if screws are tightened similarly and if excessive lubricant is visible directly after installation.

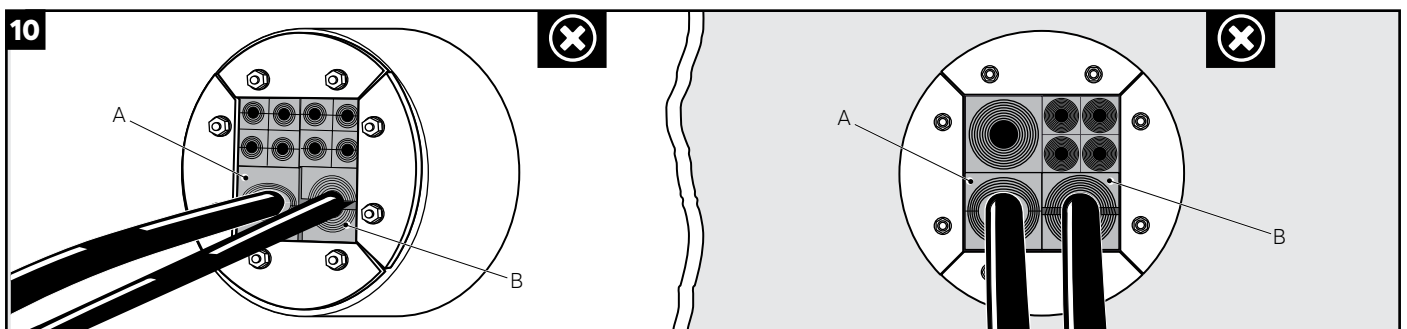

A = Too many layers removed
B = Not enough layers removed

Check that there are no visible gaps between cables/pipes and module halves. Maximum one layer difference is allowed between module halves within the same module.

Also check that front fitting still holds the modules retained after bolts are tightened.

11

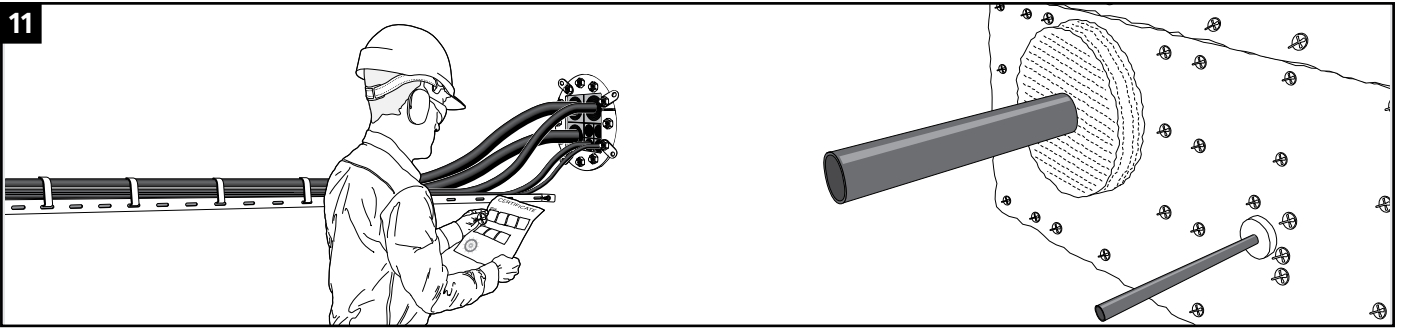

Check additional installations, if applicable.

Note

- If possible, take an overlook at the other side of the transit.
- Check additional installations according to certification requirements, e.g. insulation.

Installation checklist for round transits and seals

Project/object:

Date:

Transit name:

Full name:

Frame type:

Company:

Opening:

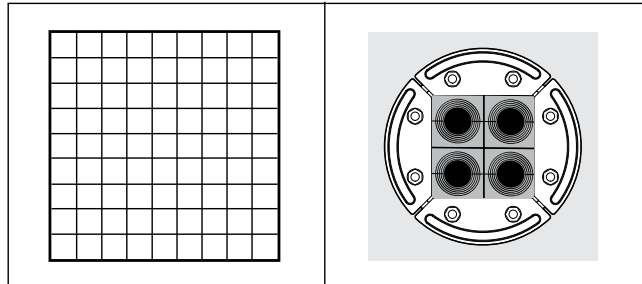

Signature:

Checkpoint Activity

OK

Not OK

Checkpoint	Activity	OK	Not OK
1	Check that the transit and packing system have no mechanical damages.		
2	Check that only one cable/pipe passes through each module or opening in a module.		
3	Check that no center cores are missing.		
4	Check that all bolts are tightened similarly.		
5	Verify that the frame is pushed all the way into the sleeve.		
6	Make sure that cables go straight through the frame.		
7	For R frames: Verify the correct utilization of the entire packing space.		
8	Make sure that the front fittings are positioned so that the modules are retained.		
9	Check the compression.		
10	Check that there are no visible gaps between cables/pipes and module halves.		

Notes:

Disclaimer

"The Roxtec cable entry sealing system ("the Roxtec system") is a modular-based system of sealing products consisting of different components. Each and every one of the components is necessary for the best performance of the Roxtec system. The Roxtec system has been certified to resist a number of different hazards. Any such certification, and the ability of the Roxtec system to resist such hazards, is dependent on all components that are installed as a part of the Roxtec system. Thus, the certification is not valid and does not apply unless all components installed as part of the Roxtec system are manufactured by or under license from Roxtec ("authorized manufacturer"). Roxtec gives no performance guarantee with respect to the Roxtec system, unless (I) all components installed as part of the Roxtec system are manufactured by an authorized manufacturer and (II) the purchaser is in compliance with (a), and (b), below.

(a) During storage, the Roxtec system or part thereof, shall be kept indoors in its original packaging at room temperature.

(b) Installation shall be carried out in accordance with Roxtec installation instructions in effect from time to time.

The product information provided by Roxtec does not release the purchaser of the Roxtec system, or part thereof, from the obligation to independently determine the suitability of the products for the intended process, installation and/or use.

Roxtec gives no guarantee for the Roxtec system or any part thereof and assumes no liability for any loss or damage whatsoever, whether direct, indirect, consequential, loss of profit or otherwise, occurred or caused by the Roxtec systems or installations containing components not manufactured by an authorized manufacturer and/or occurred or caused by the use of the Roxtec system in a manner or for an application other than for which the Roxtec system was designed or intended.

Roxtec expressly excludes any implied warranties of merchantability and fitness for a particular purpose and all other express or implied representations and warranties provided by statute or common law. User determines suitability of the Roxtec system for intended use and assumes all risk and liability in connection therewith. In no event shall Roxtec be liable for indirect, consequential, punitive, special, exemplary or incidental damages or losses.*



Roxtec International AB
Box 540, 371 23 Karlskrona, SWEDEN
+46 455 36 67 00, info@roxtec.com
www.roxtec.com